

4K UHD Wireless PTZ Camera

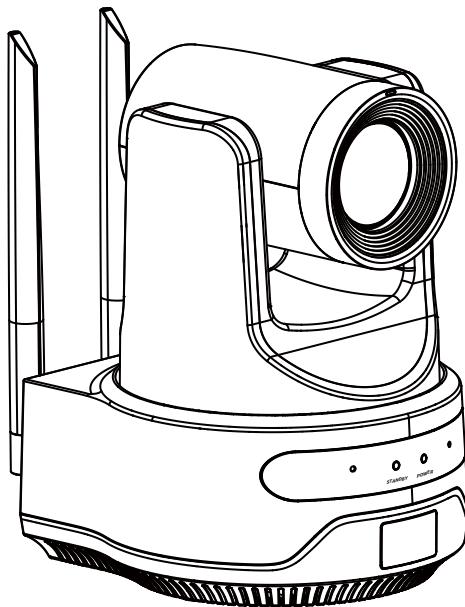

User Manual

English (V1.0)

Copyright

All contents of this manual, whose copyright belongs to our corporation cannot be cloned, copied or translated without the permission of our corporation.

Notice

Product specifications and information which were referred to in this document are for reference only. We may change, delete, or update any content at any time and without prior notice.

FCC NOTICE (Class A)



This device complies with Part 15 of the FCC Rules. The operation is subject to the following two conditions: (1) this device may not cause harmful interference, and (2) this device must accept any interference received, including interference that may cause undesired operation.



Note

This equipment has been tested and found to comply with the limits for a Class A digital device, pursuant to Part 15 of the FCC Rules. These limits are designed to provide reasonable protection against harmful interference in a residential installation. This equipment generates uses and can radiate radio frequency energy and, if not installed and used in accordance with the instructions, may cause harmful interference to radio communications. However, there is no guarantee that interference will not occur in a particular installation. If this equipment does cause harmful interference to radio or television reception, which can be determined by turning the equipment off and on, the user is encouraged to try to correct the interference by one or more of the following measures:

- Reorient or relocate the receiving antenna.
- Increase the separation between the equipment and receiver.
- Connect the equipment into an outlet on a circuit different from that to which the receiver is connected.
- Consult the dealer or an experienced radio/television technician for help.

Class A ITE

Class A ITE is a category of all other ITE which satisfies the class A ITE limits but not the class B ITE limits. Such equipment should not be restricted in its sale but the following warning shall be included in the instructions for use:



Warning

Operating this equipment in a residential environment may cause radio interference.

European Community Compliance Statement (Class A)



This product is herewith confirmed to comply with the requirements set out in the Council Directives on the Approximation of the laws of the Member States relating to Electromagnetic Compatibility Directive 2014/30/EU.

Catalogue

- 1 Safety Precautions..... 1
- 2 Packing List 1
- 3 Quick Start..... 1
- 4 About Product..... 2
 - 4.1 Features 2
 - 4.2 Specifications 3
 - 4.3 Interfaces and Keys 4
 - 4.4 Dimension..... 5
 - 4.5 Wireless Function 5
 - 4.6 Installation 6
 - 4.7 Remote Control 7
- 5 GUI Settings..... 8
 - 5.1 MENU 8
 - 5.2 EXPOSURE 8
 - 5.3 COLOR 8
 - 5.4 IMAGE 9
 - 5.5 P/T/Z..... 9
 - 5.6 NOISE REDUCTION 9
 - 5.7 SETUP 9
 - 5.8 COMMUNICATION SETUP 10
 - 5.9 AI Mode 10
 - 5.10 RESTORE DEFAULT 10
- 6 WEB Settings 11
 - 6.1 Access Camera..... 11
 - 6.2 Control Camera 11
 - 6.3 Video Settings..... 12
 - 6.4 Image Settings..... 13
 - 6.5 Audio Settings 13
 - 6.6 System Settings..... 13
 - 6.7 Network Settings..... 14
 - 6.8 Device Information..... 15
 - 6.9 Download the Upgrade Program 15
- 7 Troubleshooting 15

1 Safety Precautions

- During the installation and operation, all electrical safety regulations of the country and region of use must be strictly observed.
- Please use the power adapter that comes standard with this product.
- Do not connect multiple devices to the same power adapter (exceeding capacity of the adapter may generate excessive heat or cause fire).
- Do not rotate the camera by hand, otherwise it may cause mechanical failure.
- When installing this product on a wall or ceiling, make sure the device securely and there are no obstacles within the rotation range; Do not power on until all installations are completed.
- To avoid heat build-up, please keep smooth ventilation around the device.
- If the device smokes, smells, or makes noises,

please turn off the power and unplug the power cord immediately, then contact the dealer in time.

- This device is not waterproof, please keep the device dry.
- This product has no user serviceable parts, damage caused by disassembly by the user is not covered by the warranty.



Notice

Electromagnetic field at specific frequencies may affect the image quality.

2 Packing List

Name	Quantity
Camera	1
Power Adapter	1
Power Cable	1
Remote Control	1
Antenna	2
Lens Hood	1
User Manual	1

3 Quick Start

1) Please check connections are correct before starting.

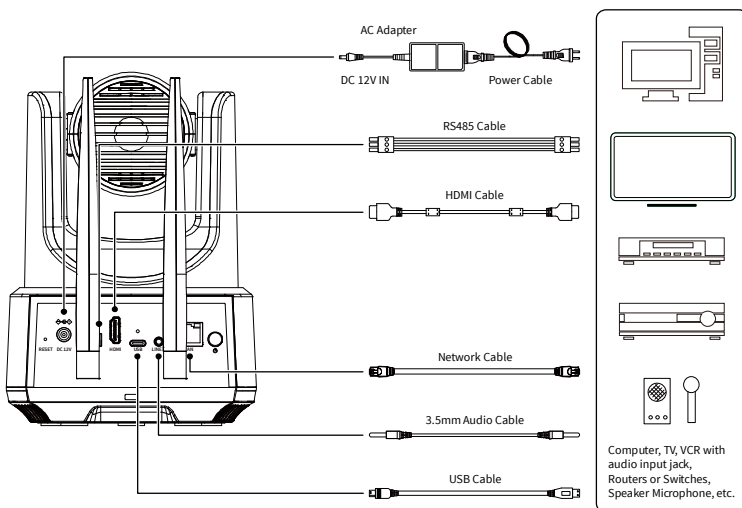

- 2) Connect the power adapter to the power connector on the rear panel of the camera. The power indicator on the front panel of the camera turns on.
- 3) After the camera is powered on, it starts to initialize, right up to the limit position, and then both horizontal and vertical go to the middle position. When the motor stops running, it indicates the initialization is completed.

4 About Product

4.1 Features

- **4K UHD**

The new high-quality 1/1.8-inch UHD CMOS sensor with 8.42 million effective pixels for ultra-high resolution up to 4K (3840x2160), downward compatible with 1080P, 720P and other resolutions.

- **AI Tracking**

With the help of the AI computing power of the chip, the camera is equipped with advanced AI algorithms to realize monocular humanoid tracking, which can realize automatic tracking of scenes such as education, conferences and live broadcasts.

- **20x Optical Zoom + 60° Wide-angle Lens**

Exclusively customized high-quality 4K ultra long focal lens, the field of view angle can reach 60°. Support 20x optical zoom and 16x digital zoom. Support night vision mode and the infrared filter can be switched automatically.

- **HDMI 1.4b**

Support HDMI 1.4b, can directly output uncompressed 4K original video.

- **Low Illumination**

The new CMOS image sensor with ultra-high SNR can effectively reduce the image noise under low illumination. The application of 2D and 3D noise reduction algorithm greatly reduces the image

noise even under the condition of ultra-low illumination, it keeps the picture clean and clear, and the SNR of image is as high as 55dB.

- **Wireless Transmission**

Stable and reliable wireless transmission, 2x2 MIMO and transmitter beamforming technology, with a maximum transmission rate of 300Mbps, strong penetration, and a transmission distance of up to 200 meters. Equipped with automatic search and intelligent configuration functions, with high transmission efficiency.

- **Remote Control**

Multiple control methods, support wireless, RS485, network, and USB to control the camera.

- **Built-in OLED Display Screen**

It can display information such as output resolution, battery power, wireless signal strength, camera status, IP address, etc.

- **Standard Lens Hood**

Standard lens hood, which can suppress image halo and prevent stray light from entering the lens. Especially suitable for wireless shooting in outdoor sunlight environments.

- **Built in Large Capacity Battery**

Built in 9450mAh ultra large capacity Li battery, with a continuous source of energy, low power design, and 5.5 hours of long-lasting battery life.

- **H.264 Slice**

The output H.264 stream supports slice encoding modes and suitable for high-end USB conference video applications.

- **USB Type-C Interface**

Full featured USB Type-C interface, compatible with USB3.0 and USB2.0, support UVC 1.1 and UAC 1.0 protocols, support the output of original and encoded video images.

- **Three Power Supply Methods**

Simultaneously supports DC 12V power adapter, Type-C, and built-in battery power supply.

4.2 Specifications

Camera	
Video System	4KP30, 4KP25, 1080P30, 1080P25
Sensor	1/1.8-inch, CMOS, Effective Pixel: 8.42M
Scanning Mode	Progressive
Lens	20x, f=6.25mm~125mm, F1.58~F3.95
Digital Zoom	16x
Minimum Illumination	0.5 Lux @ (F1.8, AGC ON)
Shutter	1/30s~1/10000s
White Balance	Auto, Indoor, Outdoor, One Push, Manual, VAR
Backlight Compensation	Support
Digital Noise Reduction	2D & 3D Digital Noise Reduction
SNR	≥55dB
Horizontal FOV	60°~3.5°
Vertical FOV	35.7°~2.0°
Pan Angle	±170°
Tilt Angle	-30°~+90°
Pan Speed	2.7°/s~35.7°/s
Tilt Speed	2.7°/s~31.5°/s
Image Flip	Support
Auto ICR	Support (Auto mode of IR Cut filter Removal)
Day/Night Mode	Support
Image Freeze	Support
Preset Position	255
Preset Accuracy	0.1°
USB Features	
Operate System	Windows 7/8/10/11, Mac OS X, Linux, Android
Color System/Compression	YUY2/MJPEG/H.264

Video Format	YUY2 (ISOC): 1440P30 (max.) MJPEG: 2160P30 (max.) H.264 AVC: 2160P30 (max.)
USB Audio	UAC 1.0
USB Protocol	UVC 1.1
UVC PTZ Control	Support
Network Features	
Video Compression	H.264/H.265/MJPEG
Video Stream	First Stream, Second Stream
First Stream Resolution	3840x2160, 1920x1080, 1280x720, 1024x576, 960x540, 640x480, 640x360
Second Stream Resolution	640x360, 480x272, 320x240, 320x180
Video Bit Rate	32Kbps~20480Kbps
Bit Rate Control	CBR, VBR
Frame Rate	50Hz: 1fps~25fps, 60Hz: 1fps~30fps
Audio Type	AAC
Audio Bit Rate	96K, 128K, 256K
Network Protocol	TCP/IP, HTTP, RTSP, RTMP(S), ONVIF, DHCP, Multicast, etc.
Wireless Features	
Work Frequency	5.15GHz~5.35GHz, 5.425GHz~5.725GHz, 5.745GHz~5.850GHz
Transmission Power	27dBm
Antenna Mode	2*2MIMO, Beamforming
Channel Bandwidth	20/40MHz
Modulation Mode	OFDM
Data Rate	300Mbps (max.)
Network Mode	Point to Point, Point to Multipoint
Penetration	1~2 walls
Transmission Distance	200M
Protocol	802.11a/n

Interface/Key	
USB Interface	1 x USB: Type-C
Video Interface	1 x HDMI: 1.4b
Network Interface	1 x LAN: 10M/100M Adaptive Ethernet Port
Audio Interface	1 x LINE IN: 3.5mm audio interface
	2 x Built-in microphone
Communication Interface	1 x RS485: 3pin phoenix port; Max Distance: 1200m; Protocol: VISCA/Pelco-D /Pelco-P
Power Interface	JEITA type (DC IN 12V)
RESET Key	Pinhole RESET

General Specifications	
Input Voltage	DC 12V
Input Current	3.0A
Battery	9450mAh
Operating Temperature	0°C~40°C
Storage Temperature	-40°C~60°C
Power Consumption	36W (max.)
Dimension	143mm x 189.3mm x 201.6mm
Net Weight	About 1.9Kg



Product specifications are subject to change without notice.

4.3 Interfaces and Keys

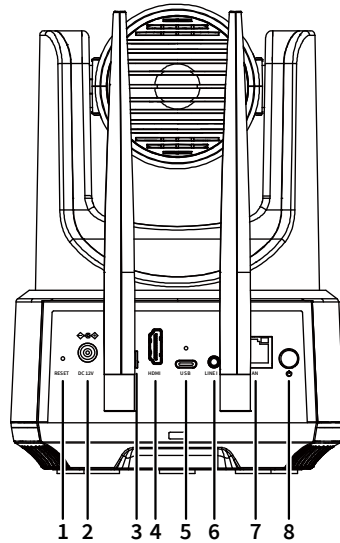

No.	Name
1	RESET Key
2	DC 12V Interface
3	RS485 Interface
4	HDMI Interface
5	USB Interface
6	LINE IN Interface
7	LAN Interface
8	Power Key

4.4 Dimension

Unit: mm

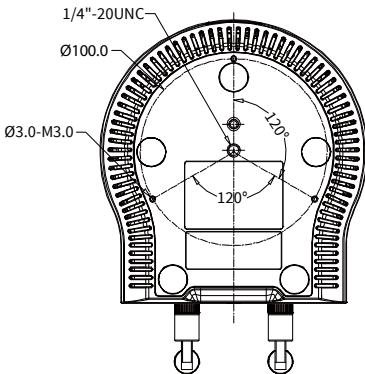
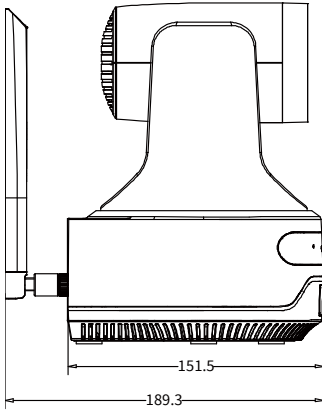
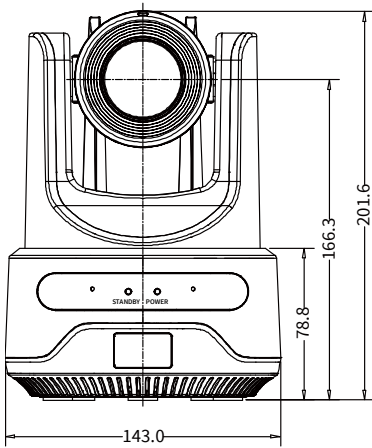

4.5 Wireless Function

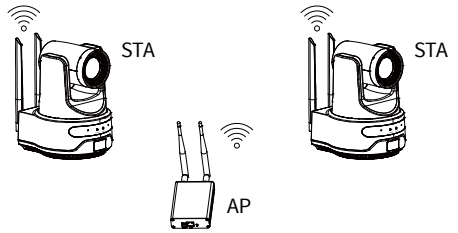

the receive box should be purchased separately



The camera can be automatically paired with the receive box. There are two methods to connect the receive box.

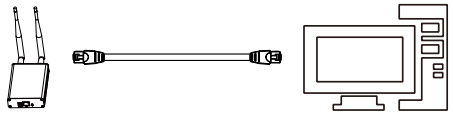

Connect by Network Cable

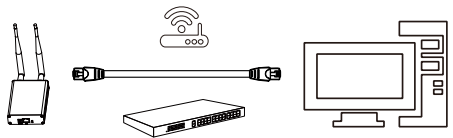

Connect by Switch/Router

4.6 Installation

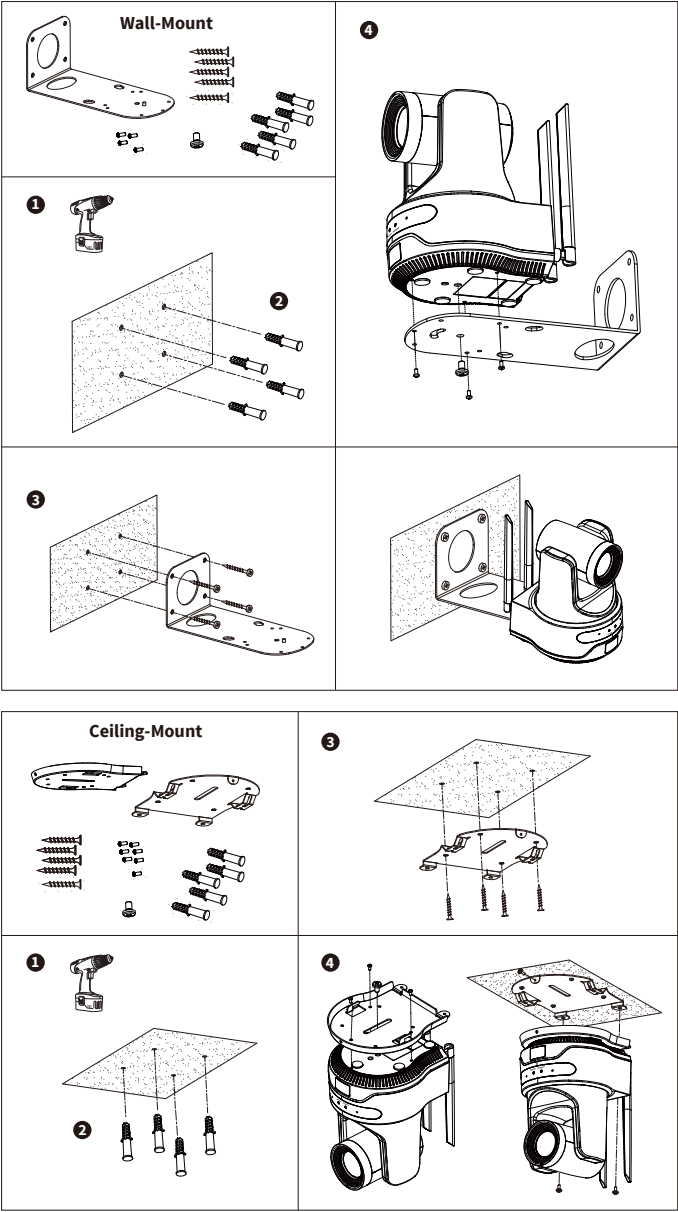

The installation diagram is for reference only.
For installation accessories, please refer to the actual product.

4.7 Remote Control

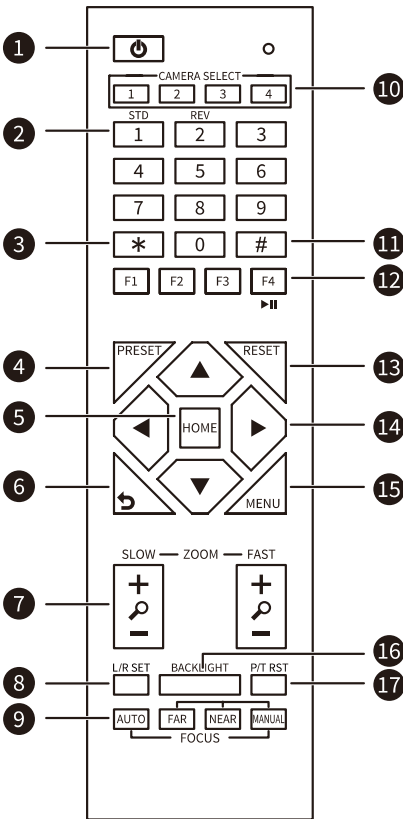

Key Description	
1. ⏻ (Standby) Key	Press to enter standby mode
2. Number Keys	To set preset or call preset
3. * Key	Use with other keys
4. PRESET Key	Set preset: Successively press [PRESET] + Number key (0-9)
5. HOME Key	Confirm selection or press to turn PTZ back to the middle position
6. ↶ (Return) Key	Press to return to the previous menu

7. ZOOM Keys

- SLOW: Zoom In [+] or Zoom Out [-] slowly
- FAST: Zoom In [+] or Zoom Out [-] fast

8. L/R SET Key

- Standard: Simultaneously press [L/R SET] + 1
- Reverse: Simultaneously press [L/R SET] + 2

9. FOCUS Keys

Auto/Manual/Far-end/Near-end focus

10. CAMERA SELECT Keys

Press to select and control the camera

11. # Key

Use with other keys

12. IR Remote Control Keys

Successively press [*] + [#] + [F1]/[F2]/[F3]/[F4]: Set address of the camera 1/2/3/4, if you want to control, press 1/2/3/4 in "CAMERA SELECT".

13. RESET Key

Clear preset position: Successively press [RESET] + Number key (0-9)

14. PTZ Control Keys

PTZ moved according to the arrow indicates

15. MENU Key

Enter OSD menu or back to the previous menu

16. BACKLIGHT Key

Backlight ON/OFF: Press repeatedly to enable or disable the backlight compensation

- Effective only in auto exposure mode
- If there is a light behind the subject, the subject will become dark, press the backlight key to enable the backlight compensation. Press again to disable this function.

17. P/T RST (PTZ Reset) Key

Press to preset Pan/Tilt self-test

Shortcut Set

[F1]: Enable Frame [F2]: No effect

[F3]: Enable Track [F4]: Exit Frame/Track

Successively press [*] + [#] + [1]: OSD menu default English

Successively press [*] + [#] + [3]: OSD menu default Chinese

Successively press [*] + [#] + [4]: Display current IP address

Successively press [*] + [#] + [6]: Quickly recover the default

Successively press [*] + [#] + [8]: Display the camera version

Successively press [*] + [#] + [9]: Quickly set up inversion

Successively press [*] + [#] + [MANUAL]: Restore to default IP address

5 GUI Settings

5.1 MENU

Press [MENU] key to display the main menu on the screen. Use the arrow key to move the cursor to desired item and press the [HOME] key to confirm to enter the corresponding sub-menu.

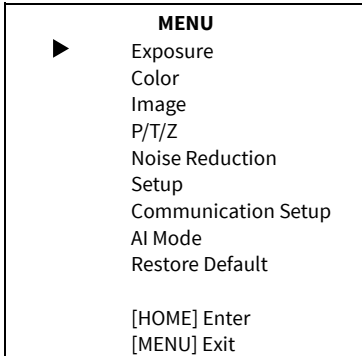

5.2 EXPOSURE

When in main menu page, move the cursor to [Exposure] and press [HOME] key to confirm to enter the Exposure page as shown as below.

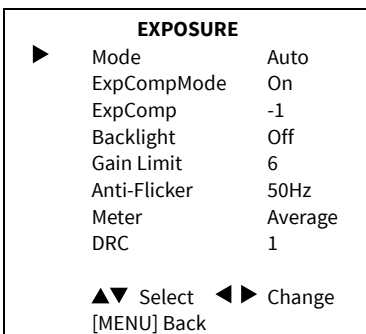

Mode: Auto, Manual, SAE, AAE, Bright.

ExpCompMode (Exposure Compensation Mode): On, Off (Effective only in Auto mode).

ExpComp (Exposure Compensation Value): -7~+7 (Effective only in ExpCompMode On).

Backlight: On, Off (Effective only in Auto mode).

Bright: 0~17 (Effective only in Bright mode).

Gain Limit: 0~15 (Effective in Auto, SAE, AAE, Bright mode).

Anti-Flicker: Off, 50Hz, 60Hz (Effective in Auto, AAE, Bright mode).

Meter: Average, Center, Smart, Top (Effective in Auto, SAE, AAE, Bright mode).

Iris: F1.8, F2.0, F2.4, F2.8, F3.4, F4.0, F4.8, F5.6, F6.8, F8.0, F9.6, F11.0, Close (Effective in Manual, AAE mode).

Shutter: 1/30, 1/50, 1/60, 1/100, 1/125, 1/180, 1/250, 1/350, 1/500, 1/725, 1/1000, 1/1500, 1/2000, 1/3000, 1/4000, 1/6000, 1/10000 (Effective in Manual, SAE mode).

Gain: 0~7 (Effective only in Manual mode).

DRC: 0~8.

5.3 COLOR

When in main menu page, move the cursor to [Color] and press [HOME] key to confirm to enter the Color page as shown as below.

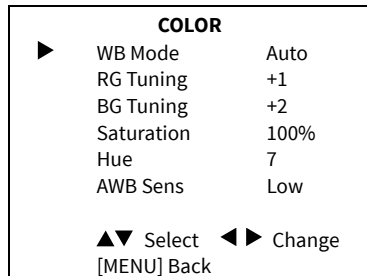

WB-Mode (White Balance Mode): Auto, Indoor, Outdoor, One Push, Manual, VAR.

RG (Red Gain): 0~255 (Effective only in Manual mode).

BG (Blue Gain): 0~255 (Effective only in Manual mode).

RG Tuning (Red Gain Tuning): -10~+10 (Effective in Auto, One Push, VAR mode).

BG Tuning (Blue Gain Tuning): -10~+10 (Effective in Auto, One Push, VAR mode).

Saturation: 60%~200%.

Hue: 0~14.

AWB Sens (The White Balance Sensitivity): High, Middle, Low (Effective in Auto, One Push mode).

Color Temp: 2500K~8000K (Effective only in VAR mode).

5.4 IMAGE

When in main menu page, move the cursor to [Image] and press [HOME] key to confirm to enter the Image page as shown as below.

IMAGE		
▶	Luminance	7
	Contrast	7
	Sharpness	6
	Flip-H	Off
	Flip-V	Off
	B&W-Mode	Off
	Gamma	0.5
	Style	Default
▲▼ Select ◀▶ Change		
[MENU] Back		

Luminance: 0~14.

Contrast: 0~14.

Sharpness: 0~15, Auto.

Flip-H: On, Off.

Flip-V: On, Off.

B&W-Mode: On, Off.

Gamma: 0.45, 0.5, 0.56, 0.63, Ext, Default.

Style: Default, Norm, Clarity, Bright, PC.

5.5 P/T/Z

When in main menu page, move the cursor to [P/T/Z] and press [HOME] key to confirm to enter the P/T/Z page as shown as below.

P/T/Z		
▶	SpeedByZoom	On
	AF-Zone	Front
	AF-Sense	High
	Display Info	On
	Image Freeze	Off
	Digital Zoom	Off
	Call Preset Speed	22
	Pre Zoom Speed	5
▲▼ Select ◀▶ Change		
[MENU] Back		

SpeedByZoom (The Depth of Field Ratio): On, Off.

AF-Zone (Auto Focus Area): Front, Top, Center, Bottom.

AF-Sense (Auto Focus Sensitivity): Low, Normal, High.

Display Info: On, Off.

Image Freeze: On, Off.

Digital Zoom: Off, 2x, 4x, 8x, 16x.

Call Preset Speed: 1~24.

Pre Zoom Speed: 0~7.

5.6 NOISE REDUCTION

When in main menu page, move the cursor to [Noise Reduction] and press [HOME] key to confirm to enter the Noise Reduction page as shown as below.

NOISE REDUCTION		
▶	NR2D-Level	Auto
	NR3D-Level	Auto
▲▼ Select ◀▶ Change		
[MENU] Back		

NR2D Level (2D Noise Reduction): Auto, Off, 1~5.

NR3D Level: (3D Noise Reduction): Auto, Off, 1~8.

5.7 SETUP

When in main menu page, move the cursor to [Setup] and press [HOME] key to confirm to enter the Setup page as shown as below.

SETUP		
▶	Language	EN
	Video Format	1080P30
	USB Mode	ISOC
	OSD Flip	Off
	Audio	On
	UVC H264	On
	Tally Mode	On
	Ircut Status	On
	Autoir High	1
	Autoir Low	1
▲▼ Select ◀▶ Change		
[HOME] Enter [MENU] Back		

Language: EN, Simplified Chinese, Russian, Traditional Chinese.

Video Format: 4KP30, 4KP25, 1080P30, 1080P25.

USB Mode: BULK, ISOC.

OSD Flip: On, Off.

Audio: On, Off.

UVC H264: On, Off.

Tally Mode: On, Off.

Ircut Status: On, Off, Auto.

Autoir High: 0~5.

Autoir Low: 0~5.

5.8 COMMUNICATION SETUP

When in main menu page, move the cursor to [Communication Setup] and press [HOME] key to confirm to enter the Communication Setup page as shown as below.

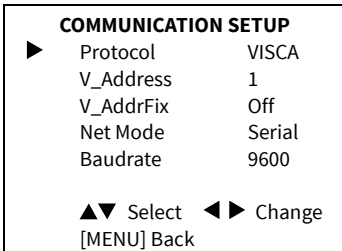

Protocol: Auto, VISCA, PELCO-D, PELCO-P.

V_Address: 1~7 (Effective in Auto, VISCA protocol).

V_AddrFix: On, Off (When set to On, the 88 30 01 FF command does not work. Effective in Auto and VISCA protocol).

P_D_Address: 0~254 (Effective in Auto, PELCO-D protocol).

P_P_Address: 0~31 (Effective in Auto, PELCO-P protocol).

Net Mode: Serial, Paral (Effective in Auto, VISCA protocol).

Baudrate: 2400, 4800, 9600, 38400.

5.9 AI Mode

When in main menu page, move the cursor to [AI Mode] and press [HOME] key to confirm to enter the AI Mode page as shown as below.

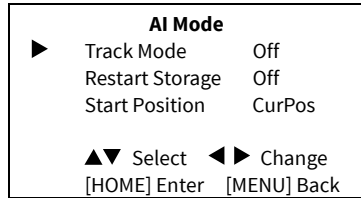

Track Mode: Off, Frame, Track.

Restart Storage: On, Off.

Start Position: CurPos, Pos0.

5.10 RESTORE DEFAULT

When in main menu page, move the cursor to [Restore Default] and press [HOME] key to confirm to enter the Restore Default page as shown as below.

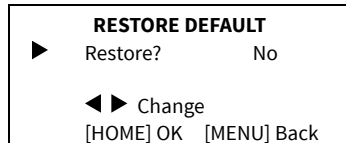

Restore: Yes, No.



Notice

When selected “Yes” and confirm with [HOME] key, all parameters will restore to default, include the IR Remote address and VISICA address.



Note

GUI menu and device information are subject to change without notice.

6 WEB Settings

6.1 Access Camera

Access <http://192.168.100.88> to pop up the login window, then input username (default: admin) and password (default: admin). After login, it will show as below:

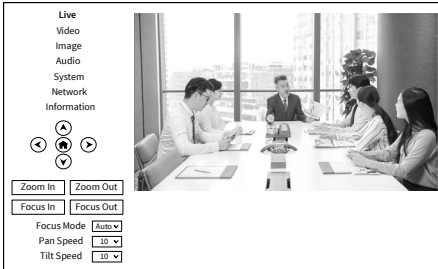

6.2 Control Camera

All pages include two menu bars:

Real Time Monitoring: Video image displaying with function buttons.

Parameter Setup: Parameter configuring.

A. Video Viewing Window

The video viewing window is same as video resolution, the bigger the resolution, the bigger the playing area. Double click the viewing window to show full screen, double click again, to return to initialized size.

Status bar in viewing window shown as below:



 Full screen switch button.

B. PTZ Setup

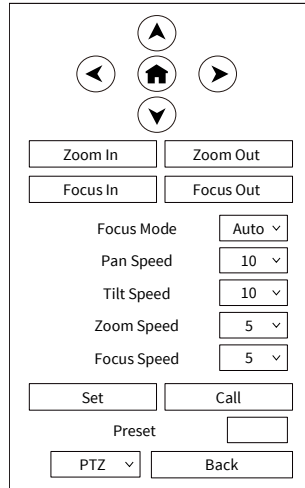

1) Pan and Tilt Control

The direction arrows and HOME button allow you to manually drive the camera to desired position.

2) Zoom

Zoom In and Zoom Out buttons allow for wide or narrow view of the space.

3) Focus

Focus In and Focus Out button allow for fine manual focus adjustment if the camera has any auto focusing problems on difficult object. The Focus Mode can be selected Auto/Manual. When you select "Manual", Focus In and Focus Out will take effect.

4) PTZ Speeds

Pan speed rate can be set to 1~24, Tilt speed rate can be set to 1~20. Zoom and Focus speed rate can be set to 1~7.

5) PTZ Presets

When the PTZ turns to the position that you would like to return to later, you can set presets for quick recall. Type a number (0~254) into the preset box and click "Set" button to save. When the PTZ turn to other position, input the

preset number and click “Call” button to turn the PTZ back to the preset position.

6) PTZ/OSD

Move the cursor to dropdown menu, select and click “OSD” to open the on-screen menu and do menu settings on the interface.

C. Language Selection



Select “Simplified Chinese”, “English”, “Russian” or “Traditional Chinese” to change the language of the webpage.

6.3 Video Settings

Video Settings		
Video Format	50Hz	
Encode Level	mainprofile	
First Stream		
Encode Codec	H264	
Resolution	3840x2160	
Bit Rate	8096	
Frame Rate	25	fps
I Key Frame Interval	25	
Bit Rate Control	CBR	
Slice Split Enable	Off	
Split Mode	Fixed bytes	
Slice Size	32	blocks/bytes
Second Stream		
Encode Codec	H264	
Resolution	320x240	
Bit Rate	1024	
Frame Rate	25	fps
I Key Frame Interval	25	
Bit Rate Control	CBR	
Slice Split Enable	Off	
Split Mode	Fixed bytes	
Slice Size	57600	blocks/bytes
<input type="button" value="Submit"/> <input type="button" value="Cancel"/>		

1) Video Format

Support 50Hz (PAL) and 60Hz (NTSC) formats.

2) Encode Level

Support baseline, mainprofile and highprofile.

3) Encode Codec

Support H264, H265 and MJPEG.

4) Resolution

First stream support 3840x2160, 1920x1080, 1280x720, 1024x576, 960x540, 640x480, 640x360. Second stream support 640x360, 480x272, 320x240, 320x180; The bigger the resolution, the clearer the image, and the larger the code stream, the more network bandwidth will be taken.

5) Bit Rate

You can specify the bit rate, the larger of the bit rate, the clearer of the image. The configuration of the bit rate needs to be combined with the network bandwidth. When network bandwidth is narrow and the bit rate is configured larger, the video stream cannot be transmitted normally, and the visual effect will be worse.

6) Frame Rate

You can specify the size of the frame rate, the greater the frame rate, the smoother the image, the smaller the frame, the more sense of beating.

7) I Key Frame Interval

Set the interval between two I frames, the bigger the interval, the slower the response when opening the image for the first time.

8) Bit Rate Control

Two modes for bit rate control:

CBR (Constant Bit Rate): Video coder will be coding according to the preset speed.

VBR (Variable Bit Rate): Video coder will adjust the speed based on preset speed to gain the best image quality.

9) Slice Split Enable

Enable or disable the Slice Split function.

10) Split Mode

Split Mode Fixed bytes.

11) Slice Size

Size for slice.

6.4 Image Settings

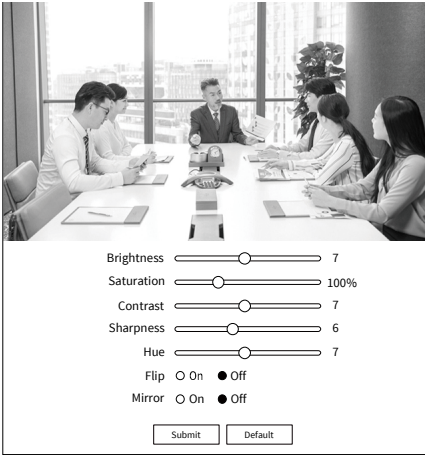

1) Brightness

Brightness of image: 0~14 (Default is 7).

2) Saturation

Saturation of image: 60%~200% (Default is 100%).

3) Contrast

Contrast of image: 0~14 (Default is 7).

4) Sharpness

Sharpness of image: 0~15, auto (Default is 6).

5) Hue

Hue of image: 0~14 (Default is 7).

6) Flip & Mirror

Turn On/Off the Flip function.

Turn On/Off the Mirror function.

6.5 Audio Settings

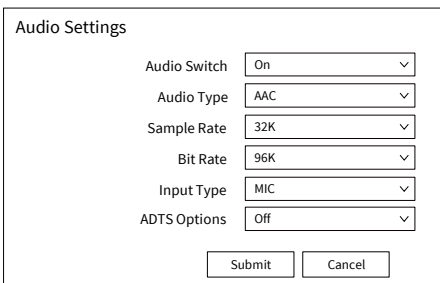

1) Audio Switch

Turn On/Off the audio switch.

2) Audio Type

Audio type AAC.

3) Sample Rate

Sample rate 32K.

4) Bit Rate

Bit rate 96K, 128K and 256K selectable.

5) Input Type

Input type MIC, LINE IN and MIX selectable.

6) ADTS Options

Options: On/Off.

6.6 System Settings

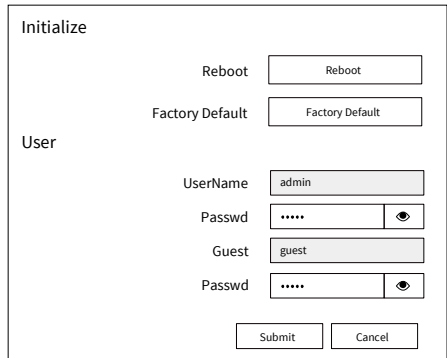

1) Reboot

Click "Reboot" to restart system.

2) Factory Default

Click "Factory Default" to restore factory settings.

3) Username and Password

Modify the password of username and guest (only use letters and numbers, the max password length is 32 bits).

6.7 Network Settings

Lan Settings

IP Configuration Type

IP Address

Subnet Mask

Gateway

DNS Address

MAC Address

Port Settings

HTTP Port

RTSP Port

TCP Port

UDP Port

Sony Visca

RTMP(S) Settings

First Stream On Off Video Audio

MRL

Second Stream On Off Video Audio

MRL

SRT Settings

SRT On Off

SRT Mode

SRT Server

SRT Port

SRT Encryption

SRT Password

SRT Bandwidth Overhead

SRT Variable Latency

SRT StreamID

RTSP Settings

RTSP Auth On Off

ONVIF Settings

ONVIF On Off

ONVIF Auth On Off

Multicast Settings

Multicast On Off

Address

Port

NTP Settings

NTP Time Sync On Off

Time Zone

Server Address

Time Interval (min)

Main Time Show On Off

Position

Sub Time Show On Off

Position

1) Lan Settings

The default camera IP: 192.168.100.88.
The MAC address cannot be modified.

2) Port Settings

A. HTTP Port

The IP address identifies a network device and multiple network programs can run on the device, each network program uses the network port for data transmission. The port setting on this page is to set up which port the WEB SERVER program uses to transmit. During port mapping, it needs to be consistent with the port number (default is 80).

B. RTSP Port

Set up the RTSP port, default is 554.

C. TCP Port

Set up the TCP port, default is 5678.

D. UDP Port

Set up the UDP port, default is 1259.

E. Sony Visca

Sony Visca 52381.

3) RTMP(S) Settings

Set the MRL of RTMP(S) and select “On”, “Off”, “Video” and “Audio” functions to enable or disable video and audio in the two streams. Click “Submit” and restart to take effect.

4) SRT Settings

Turn On/Off SRT and set up the SRT Mode, SRT Server, SRT Port, SRT Encryption, SRT Password, SRT Bandwidth Overhead, SRT Variable Latency and SRT StreamID.

5) RTSP Settings

Turn On/Off the RTSP Auth.

6) ONVIF Settings

Turn On/Off the ONVIF and ONVIF Auth.

7) Multicast Settings

Turn On/Off Multicast, set up Multicast Address (default is 224.1.2.3) and Port (default is 6688; 6688 is the multicast port of the first stream and 6690 is the multicast port of the second stream).

8) NTP Settings

Turn On/Off NTP Time Sync, Main Time Show and Sub Time Show; select the Time Zone; set up the Server Address, Time Interval and the Time Show Position of the two streams.

6.8 Device Information

Information	
Device ID	<input type="text" value="UHD Camera"/>
Device Type	<input type="text" value="F66.SR"/>
Software Version	<input type="text" value="SOC v9.1.08 - ARM 7.3.12S"/>
Webware Version	<input type="text" value="v1.5.6"/>
<input type="button" value="Submit"/> <input type="button" value="Cancel"/>	

6.9 Download the Upgrade Program

If you need the camera upgrade program, please contact the manufacturer.



WEB interface and device information are subject to change without notice.

7 Troubleshooting

Image

- The monitor shows no image
 - 1) Ensure that the camera power supply is connected, the voltage is normal, and the power indicator is always on.
 - 2) Turn off the power switch to check that the camera is self-testing.
 - 3) Ensure the cable of video platform and TV that in correct connection.
- Image jitters after the camera is properly connected
 - 1) Ensure that the camera installation is in stable position.
 - 2) Check that any vibrating machinery or object near the camera.

- There is no video image in browser

That do not support IE browser and IE core browser, it is recommended to use Google, Firefox and Edge browsers. The camera video image will be displayed normally.

- Unable to access through the browser
 - 1) Using PC to access the network to test that the network access can work properly to eliminate the network fault caused by cable and PC virus until the PC and camera can ping each other.
 - 2) Disconnect the network, connect camera with PC separately and reset the IP address of PC if necessary.
 - 3) Ensure that the IP address, subnet mask and gateway settings is correct.
 - 4) Check that the MAC address is conflicts.
 - 5) Check that the web port is modified, the default setting is 80.
- Forget the IP address or login password

The default IP address is: 192.168.100.88; the default username and password are: admin.

Control

- Remote control does not work
 - 1) Check and replace with new batteries.
 - 2) Ensure that the camera working mode is correct.
 - 3) Ensure that the address key of remote control can match the camera.
- Serial port cannot control
 - 1) Ensure that the protocol, address and bit rate of the camera are consistent.
 - 2) Ensure that the control cable is properly connected.



079.79.1101537_V1.0